



N-610LY, N-630LY, Rope Grab INSTRUCTIONS AND WARNING INFORMATION

User Instruction Manual N-610LY, N-630LY Rope Grab Version

This manual is intended to meet the Manufacturer's Instructions as required by CSA Z259.2.5 and ANSI Z359.15 and should be used as part of the employee training program.

WARNING: This product is part of a personal fall arrest or restraint system. The user must read and follow the manufacturer's instructions for each component or part of the complete system. These instructions must be provided to the user of this equipment. The user must read and understand these instructions or have them explained to them before using this equipment. Manufacturer's instructions must be followed for proper use and maintenance of this product. Alterations or misuse of this product or failure to follow instructions may result in serious injury or death.

IMPORTANT: If you have questions on the use, care, or suitability of this equipment for your application, contact Yoke Industrial.

IMPORTANT: Before using this equipment, be sure to log relevant information in the Inspection and Maintenance Log at the back of this manual.

DESCRIPTION:

Key components of the Yoke N610LY, N630LY Rope Grab Models are depicted in the drawing below. These Rope Grab Models are designed for connection to APPROVED 5/8" rope only. The N610LY, N630LY are trailing rope grabs – they are designed to automatically 'follow' the user along the rope and may be purposefully detached by the user anywhere on the lifeline.

A	Lanyard Connection Handle
B	Gravity Lock
C	Enclosure
D	Roller Cam
E	Locking Roller
F	Detent Pin
G	Warning Marking
H	Energy Absorber

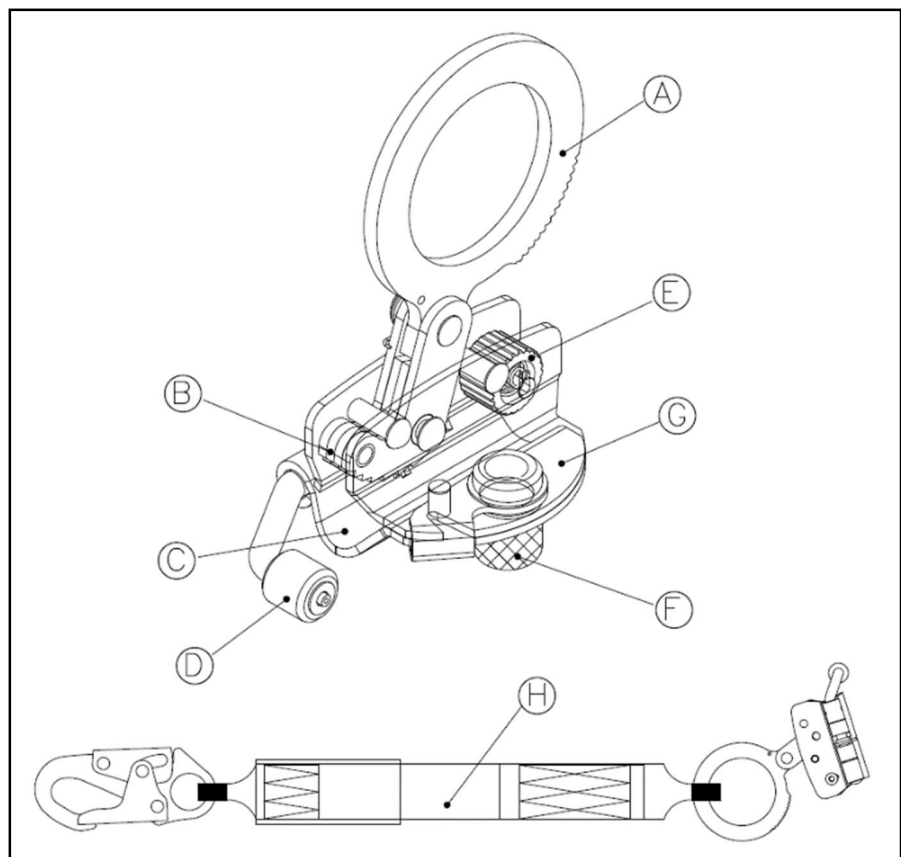

Figure 1– 16mm(5/8") Rope Grab

A. APPLICATIONS

- A. 1 PURPOSE:** The N610LY, N630LY rope grabs are intended to be used as part of a personal fall arrest system. Applications for these rope grabs include most activities where there exists the need for fall arrest or restraint (on sloped surfaces) Figures 2 and 3 are examples of these applications. This rope grab is a part of a complete fall arrest system, including approved lifeline (only lifelines listed in these instructions can be used), integrally attached shock absorbing lanyard (supplied with N610LY, N630LY – only these shock absorbing lanyards can be used) and full body harness. Maximum permissible free fall is 1.8 m (6 feet). The rope grab can ONLY be used with the supplied integrally attached shock absorbing lanyard.

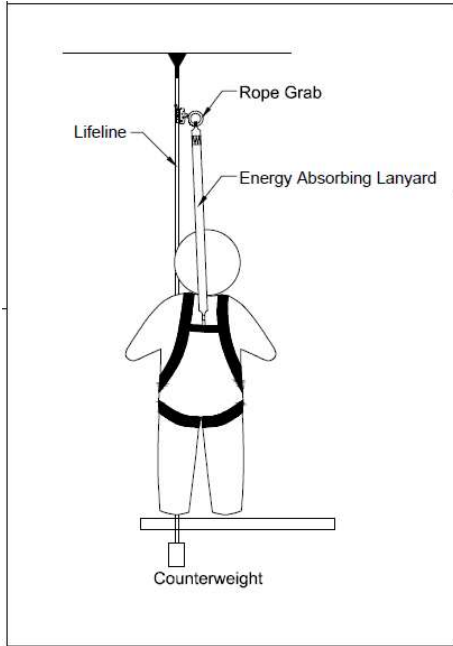

Figure 2– Fall Arrest

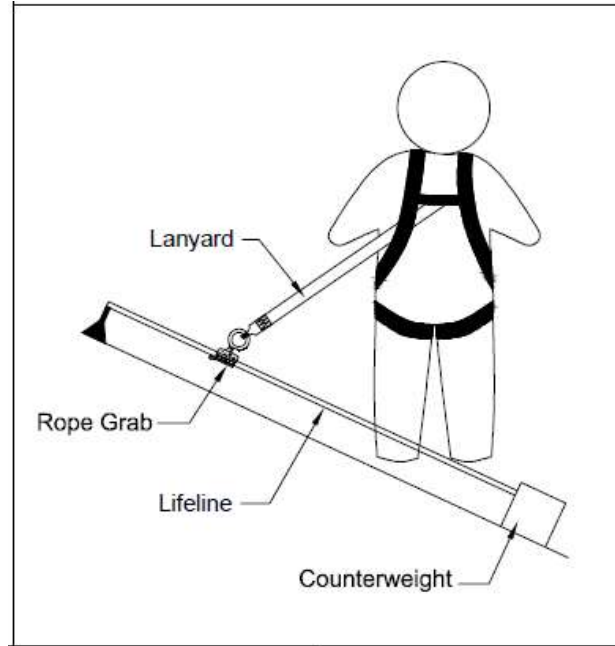

Figure 3– Restraint

- A. 2 LIMITATIONS:** Always consider the following limitations and requirements when installing or using this equipment.
- a CAPACITY:** The N610LY and N630LY rope grabs with integrally attached shock absorbing lanyard are designed for use by persons with a combined weight (person, clothing, tools, etc.) of between 45kg (100 lbs) and 160 Kg (352 lbs) NOTE: No more than one person may be attached to a single lifeline.
 - b FREE FALL:** Fall Protection / Restraint systems must be rigged such that there is no possible vertical free fall. The N610LY and N630LY rope grabs can only be used with the supplied, integrally attached shock absorbing lanyard and the system must be rigged to limit the free fall to 1.8 m (6 feet) or less per (CSA Z259.2.5). See associated connecting subsystem manufacturer's instructions for additional information.
 - c FALL CLEARANCE:** Make certain that enough clearance exists in your fall path to prevent striking an object. The amount of clearance required is dependent upon the type of connecting subsystem used, the anchorage location, and the amount of stretch in the lifeline, free fall distance, and deceleration distance.
 - d CORROSION:** Do not leave this equipment in environments where corrosion of metal parts could take place (i.e. as a result of vapors from organic materials, sewage and fertilizer plants, corrosive chemicals, etc). Use of these rope grabs near seawater or other corrosive environments may require more frequent inspections or servicing to ensure corrosion damage is not affecting the performance of the product.
 - e CHEMICAL HAZARDS:** Exposure of these grabs to corrosive or caustic liquids may cause damage to this equipment and affect is safe use. When working with such chemicals, frequent inspection of this equipment must be performed. Consult Yoke Industrial if there is a doubt concerning use of N610LY, N630LY around chemical hazards.
 - f HEAT:** The N610LY, N630LY are designed for use in high temperature environments. Protection should be provided for this equipment when used near welding, metal cutting, or similar activities. Hot sparks may burn or damage this equipment and affect its safety.
 - g ELECTRICAL HAZARDS:** Due to the possibility of electric current flowing through this equipment or connecting components, use extreme caution when working near high voltage power lines.

- h **COMPONENT COMPATIBILITY:** The N610LY, N630LY rope grabs can only be used with approved lifelines.
- A. 3 **TRAINING:** This equipment is to be used by persons who have been properly trained in its correct application and use.
- A. 4 **REQUIREMENTS:** Refer to applicable local, state, and federal requirements governing this equipment for more information on rope grabs and associated system components; including CSA Z259.2.5.
- A. 5 **RESCUE PLAN:** When using this equipment, the employer must have a rescue plan and the means to implement the rescue. The plan must also be communicated to the plan users, authorized personnel and the rescuers as well.
- A. 6 **INSPECTION BEFORE USE:** The rope grab must be inspected according to procedures in Section C of this manual.

B. SYSTEM REQUIREMENTS

B. 1 COMPATIBILITY OF COMPONENTS: The N610LY, N630LY rope grabs are designed for use with approved components and subsystems only. Substitutions or replacements made with non-approved components or subsystems may affect jeopardize compatibility of equipment and safety, thereby affecting the safety of the entire system. The N610LY and N630LY rope grabs are CSA Z259.2.5 approved when used with the following synthetic lifelines:

- **16mm MCM Superline Rope (from MCM Ropes & Rigging)**
- **57-316 16mm Rope (from Cancord)**

B. 2 COMPATIBILITY OF CONNECTORS: Fall Protection connectors (i.e. Hooks, Carabiners, D-rings) are compatible with connecting elements when they have been designed to work together in such a way that their sizes and shapes do not cause their gate mechanisms to inadvertently open.

Connectors must be capable of supporting at least **23kN** (5,000 lbs.) and must be compatible with the connecting anchorage or other system components. Do not use equipment that is not compatible, since non-compatible connectors may unintentionally disengage. (See Figure 4.) In order to be compatible, connectors must be compatible in size, shape, and strength. If the a connector is attached to a system / anchoring component that is undersized or irregular in shape, during use or a fall situation, force may be applied to the gate of the connector causing the gate to open and the connector to potentially disengage from the system / anchoring component.

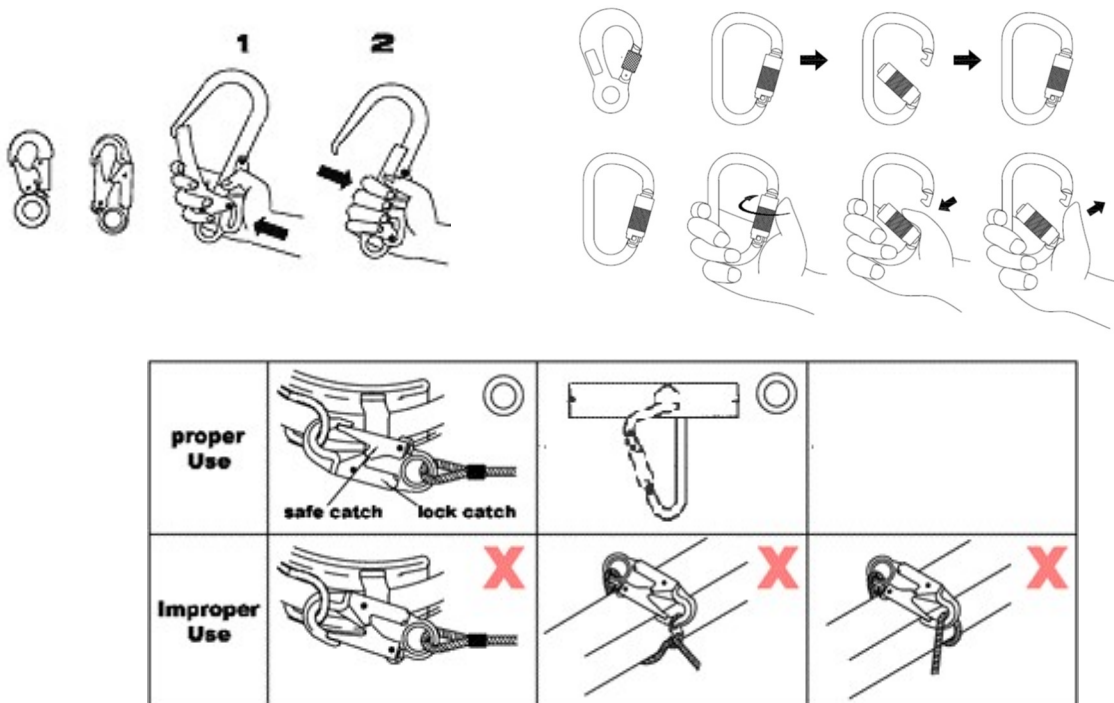

Figure 4– Application for safety hook

B. 3 MAKING CONNECTIONS: Use only Yoke supplied, integrally attached shock absorbing lanyard with double, self-locking connector. Ensure compatibility (size, shape, strength) of connectors used and ensure all connectors are fully closed and locked.

ANCHORAGE STRENGTH: Anchorages selected for use with the N610LY, N630LY rope grabs must have a strength capable of sustaining the static load requirements of the intended fall protection application:

- a **FALL ARREST:** Anchorages selected for fall arrest systems shall have a strength capable of sustaining static loads applied in the directions permitted by the system of at least: **23kN** (5,000 lbs) for non-certified anchorages. When more than one fall arrest system is attached to an anchorage, the strengths shall be multiplied by the number of systems attached to the anchorage.

OSHA 1926.500 AND 1910.66: Anchorages used for attachment of PFAS shall be independent of any anchorage being used to support or suspend platforms, and capable of supporting at least 23kN (5,000 lbs) per user attached, or be designed, installed, and used as part of a complete PFAS which maintains a safety factor of at least two, and is supervised by a qualified person.

B. 4 LIFELINE REQUIREMENTS: The N610LY and N630LY rope grabs are CSA Z259.2.5 approved when used with the following synthetic lifelines:

- **16mm MCM Superline Rope (from MCM Ropes & Rigging)**
- **57-316 16mm Rope (from Cancord)**

B. 5 SIZE: The N610LY, N630LY are designed to be used only with the approved 5/8-inch (16mm) diameter lifelines specified above. Lifelines not approved / undersized lifelines may NOT be used with N610LY, N630LY since the rope grab may not lock properly and may lead to excessive stopping distances OR inability of grab to arrest the fall. Oversized rope may impede rope grab mobility on the lifeline.

***IMPORTANT:** CSA Z259.2.5 mandates the lower end of the lifeline have a termination that prevents the fall arrester from passing through that termination. When the line is installed, the bottom end shall also have a counterweight to provide stiffness. Knots shall not be used for load bearing end terminations.*

B. 6 CONNECTING THE LANYARD: The N610LY, N630LY rope grabs can only be used with supplied integrally attached shock absorbing lanyard. The rope grab, shock absorbing lanyard and lifelines have all been tested by CSA to meet or exceed requirements of CSA Z259.2.5.

B. 7 BODY SUPPORT: The required body support is a full body harness. **USE ONLY APPROVED FULL BODY HARENSS.**

***Warning:** Do not alter or intentionally misuse this equipment. Do not use this equipment if you are unable to tolerate the impact from a fall arrest. Age and fitness can seriously affect your ability to withstand a fall. Pregnant women and minors must not use this equipment.*

C. SYSTEM REQUIREMENTS

- C.1 BEFORE EACH USE OF THE N610LY, N630LY** carefully inspect to ensure that it is in good working condition (see section E). Do not use if inspection reveals an unsafe condition.
- C.2 PLAN** your fall arrest or restraint system before starting your work. Consider all factors that affect your safety before, during, and after a fall. Refer to these and related subsystem component instructions, and state and federal safety regulations for guidance in planning your system. Examples of items to be considered:
 - a **ANCHORAGE:** Select a rigid anchorage point that is capable of supporting the required loads. The anchorage location must be carefully selected to reduce possible free fall and swing fall hazards and to avoid striking an object during a fall. For fall arrest systems OSHA requires the anchorage be independent of the means suspending or supporting the user.
 - b **FREE FALL:** Do not work above the anchorage point. Personal fall arrest systems must be rigged such that the potential free fall is never greater than **1.8 m (6 feet)**.
 - c **FALL ARREST FORCES:** The fall arrest system will limit the fall arrest forces to 4kN (900 lbs) with the supplied integrally attached shock absorbing lanyard
 - d **SWING FALLS:** Swing falls occur when the anchorage point is not directly above the point where a fall occurs (Figure 5). The force of striking an object while swinging can be great and cause serious injury.
 - e **FALL CLEARANCE:** Make certain enough clearance exists in your fall path to prevent striking an object (Figure 6). This required clearance **MUST** be determined **PRIOR TO EACH USE OF N610LY, N630LY**.
 - f **SHARP EDGES:** **DO** not work where parts of the system will be in contact with, or abrade against, unprotected sharp edges.

- g **RESCUE:** The user must have a rescue plan and the means at hand to implement it if a fall occurs.
- h **AFTER A FALL:** If the N610LY, N630LY have been subjected to the forces of arresting a fall, they **must be removed from service immediately and destroyed.**
- i **CONSIDERATIONS:** Avoid working where lifeline may cross or tangle with that of another worker. Do not allow the lanyard to pass under arms or between legs. Do not clamp, tie, or otherwise prevent the rope grab lanyard connection handle from moving freely into the “locked” position.
- j **SLOPED ROOFS:** Provisions must be made (warning lines, monitors, guardrails) to prevent swing falls from unprotected roof edges or corners. The rope grab should be connected to the full body harness using the supplied integrally attached shock absorbing lanyard by means of a direct connection to the user’s harness. The supplied integrally connected shock absorbing lanyard must be protected from contact with sharp or abrasive edges and surfaces. The rope grab locking operation must not be hindered by interference with the roof or objects on the roof surface.
- k **UNSTABLE SURFACES:** The N610LY, N630LY rope grabs are not suitable for use on unstable or slowly shifting materials.

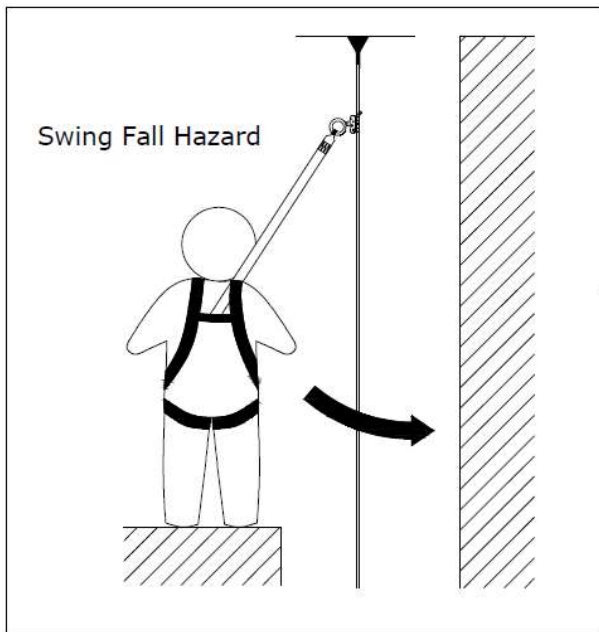

Figure 5– Swing Falls

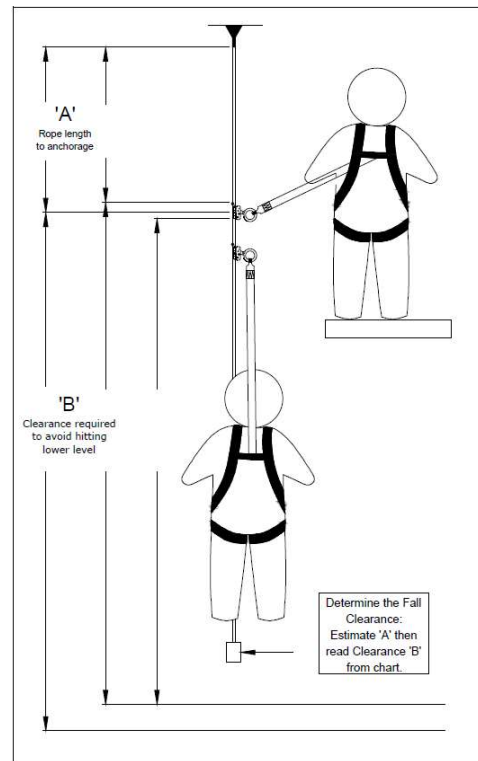

Figure 6– Fall Clearance

C.3 ATTACHING THE N610LY, N630LY TO THE LIFELINE:

- a Ensure the N610LY, N630LY rope grab is in the “UP” position as indicated by the arrow and the word UP on the rope grab. The “UP” end of the rope grab must be oriented towards the anchorage when installed onto the lifeline. NOTE: The rope grab hinge incorporates a lock which will prevent the hinge from closing if the rope grab is not held upright.
- b Test the operation of the rope grab by pulling down on the supplied integrally attached shock absorbing lanyard. You must not be able to pull the rope grab down the lifeline once the locking cams have fully engaged the lifeline.

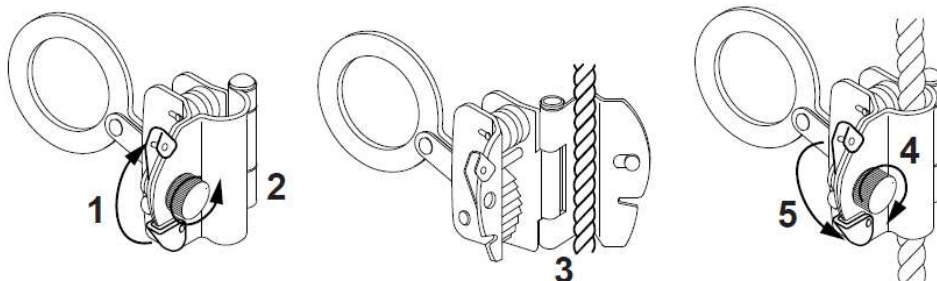

Figure 7– Attaching to Lifeline

C.4 POSITIONING N610LY, N630LY ON THE LIFELINE:

NOTE: ONLY PERFORM THE FOLLOWING POSITIONING WHEN THE USER IS SAFELY ON GROUND OR HAS ALTERNATE FALL PROTECTION ATTACHED.

- a Using the supplied integrally attached shock absorbing lanyard connectd to the N610LY, N630LY, pull up slightly on the rope grab to release it from its current position. Lift the ring if necessary. Note during use - Always keep a minimum of 4.7m (15.4 ft) of rope below the rope grab for fall clearance with an E4 Energy Absorber.

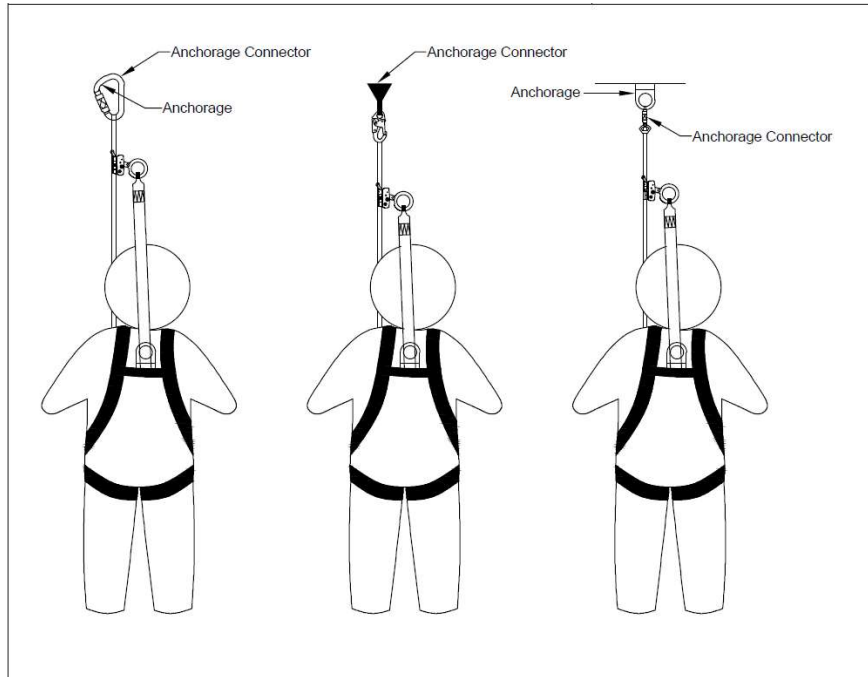

Figure 8– Making the Connection

- b Using the connected shock absorbing lanyard, raise or lower the rope grab to the desired new position. Tension the lifeline to assure smooth motion of the rope grab on the lifeline. To tension the lifeline, extend 15-22m (50 to 75 feet) of lifeline below the rope grab, or secure the end of the lifeline at working or ground level, or use a six to ten pound counterweight. The method of tensioning used should be determined by job site conditions.
- c After moving the rope grab to a new position, position it at or above shoulder height to reduce possible free fall. Lock the rope grab at this position by pulling the attached shock absorbing lanyard

Warning: Rope grab attachment and positioning instructions and procedures must be followed. Improper assembly could allow the rope grab to slip or not lock onto the lifeline in the event of a fall and may result in serious injury or death.

C.5 CONNECTING TO THE FULL BODY HARNESS: connect to the dorsal D-ring located between the shoulders on the back of the full body harness. Ensure connections are compatible in size, shape, and strength. Refer to the full body harness manufacturer's instructions for more information on making connections.

C.6 NOTE : The N610LY, N630LY are supplied with integrally attached shock absorbing lanyard - do not attempt to attach additional lanyards, connectors or remove the attached shock absorbing lanyard. Doing so may result in serious injury or death.

C.7 USE OF LIFELINES: (See Lifeline User Instruction Manual for complete details)

- Always protect the lifeline if passing over or around sharp edges. Sharp edges can reduce rope strength by 70% or more.
- Keep lifelines clean.
- Avoid twisting or kinking lifelines when coiling or uncoiling.
- Avoid using lifelines near acids or alkalines. If the lifeline is used around any chemical or compound, watch for signs of deterioration.
- Never use a knotted lifeline, knots can reduce rope strength by 50%.
- Always connect a counterweight to lifeline for stiffness as mandated per CSAZ259.2.5.

- Store lifelines properly.

C.8 AFTER USE OF THE ROPE GRAB AND ITS SUBSYSTEM COMPONENTS: Return it for cleaning or storage

D. TRAINING

D.1 TRAINING: The user, and the user’s employer, must be trained in the correct use and care of this equipment. Both parties must be aware of the operating characteristics, application limits, and consequences of improper use of this equipment.

E. INSPECTION

IMPORTANT: Training must be conducted without exposing the trainee to a fall hazard. Training should be repeated on a periodic basis as determined by applicable regulating body, employer.

E.1 FREQUENCY

- a Before each use, visually inspect the equipment per steps listed below.
- b The rope grab must be inspected by a *competent person*¹ other than the user at least annually. See Sections below for inspection guidelines. Record the results of each formal inspection in the inspection log found in this manual.

IMPORTANT: If the N610LY, N630LY rope grab has been subjected to fall arrest or impact forces, it must be immediately removed from service and destroyed.

E.2 INSPECTION OF N610LY, N630LY

Competent person: One who is capable of identifying existing and predictable hazards in the surroundings or working conditions which are unsanitary, hazardous, or dangerous to employees, and who has authorization to take prompt corrective measures to eliminate them.

E.3 INSPECTION FOR LIFELINES (See Lifeline User instruction manual for complete details)

- Step 1.** Lifeline hardware must not be damaged, broken, distorted, or have any sharp edges, burrs, cracks, worn parts, or corrosion. Ensure the connecting hooks work properly. Hook gates must move freely and lock upon closing.
- Step 2.** Inspect the rope for concentrated wear. The material must be free of frayed strands, broken yarns, cuts, abrasions, burns, and discoloration. The rope must be free of knots, excessive soiling, heavy paint buildup, and rust staining. Rope splices must be tight, with five full tucks, and thimbles must be held by the splice. Cracked or distorted rope thimbles may indicate that the lifeline has been impact loaded. Check for chemical or heat damage (indicated by brown, discolored, or brittle areas). Check for ultraviolet damage, indicated by discoloration and the presence of splinters and slivers on the rope surface. All of the above factors are known to reduce rope strength. Damaged or questionable ropes must be replaced.
- Step 3.** Inspect labels. All labels must be present and fully legible. If labels missing or illegible, contact lifeline manufacturer.
- Step 4.** Record the inspection date and results in the inspection log found in the Lifeline User Instruction Manual.

E.4 IF INSPECTION REVEALS A DEFECTIVE CONDITION: Remove the unit from service immediately and destroy.

IMPORTANT: Do not attempt to alter, repair, or make substitutions to the rope grab or rope grab parts. Equipment found to be in defective condition must be removed from service. Repairs can only be performed by Yoke Industrial.

F. STORAGE

F.1 Store the rope grab and lifeline in a cool, dry, clean environment out of direct sunlight. Avoid areas where chemical vapors may exist. Thoroughly inspect the rope grab and lifeline after any period of extended storage.

MATERIAL:

- Material: All material used in the construction is certified to be new and free from defects.
- Construction: Riveted with removable detent pin.

G. PERFORMANCE DATA

- Arrest Force: Designed for 6 kN (1350 lbs) maximum arresting force with an energy absorbing lanyard.
- Maximum Capacity: **160 Kg (352 lbs)** when using an energy absorbing lanyard.
- Requirements: Meets applicable local and federal standards, Z259.2.5, Z359.15

H. ROPE GRAB MARKINGS

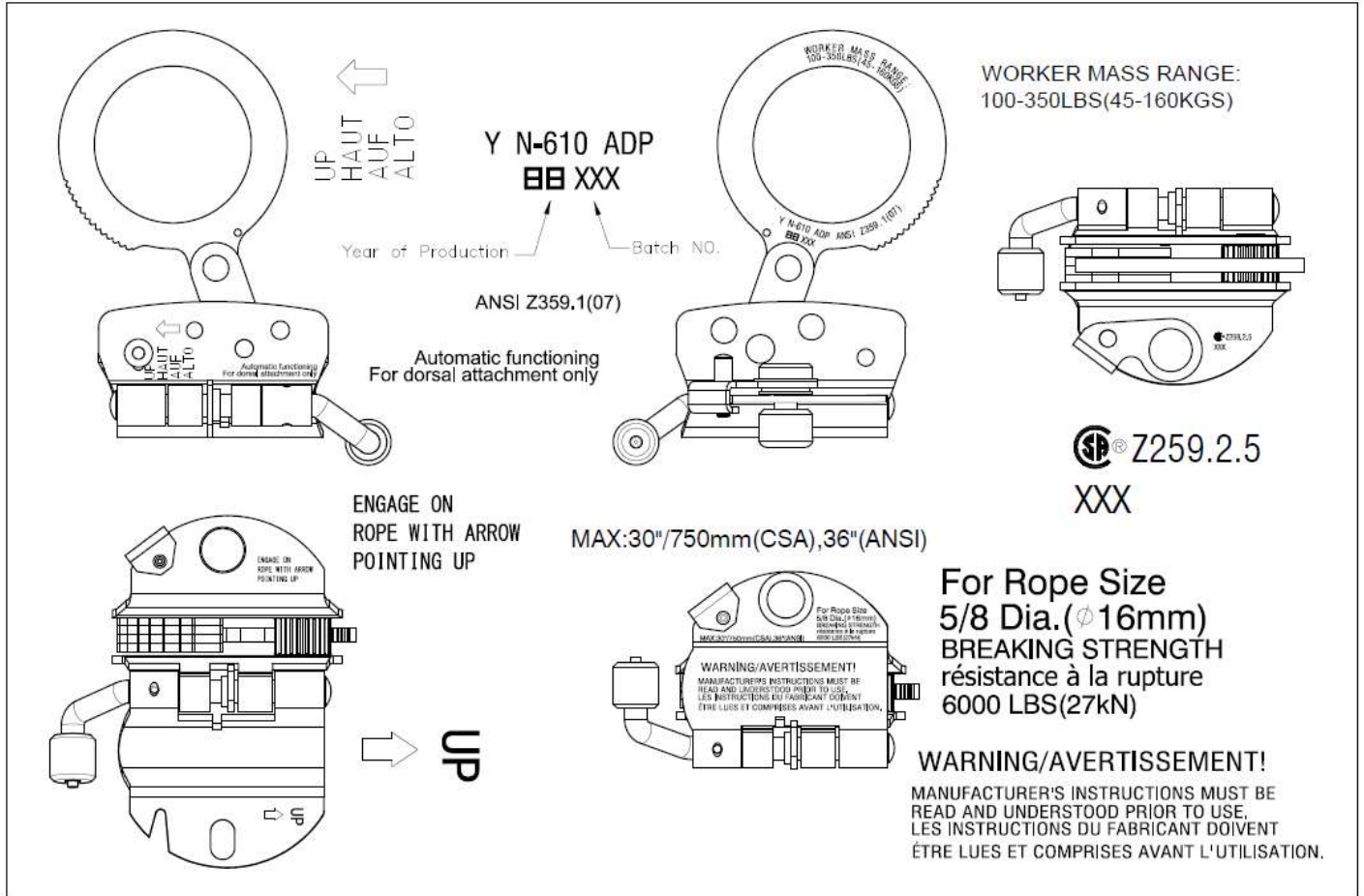

Figure 9– Markings

INSPECTION AND MAINTENANCE LOG

Purchase date	Service entry date	User's name
---------------	--------------------	-------------

INSPECTION CHECK LIST

DATE	NOTE	CORRECTIVE ACTION TAKEN	PERFORMED BY	SIGNATURE
	PASS <input type="radio"/>	RETURN TO REPAIR <input type="radio"/>		
	FAIL <input type="radio"/>	DESTROY <input type="radio"/>		
	PASS <input type="radio"/>	RETURN TO REPAIR <input type="radio"/>		
	FAIL <input type="radio"/>	DESTROY <input type="radio"/>		
	PASS <input type="radio"/>	RETURN TO REPAIR <input type="radio"/>		
	FAIL <input type="radio"/>	DESTROY <input type="radio"/>		
	PASS <input type="radio"/>	RETURN TO REPAIR <input type="radio"/>		
	FAIL <input type="radio"/>	DESTROY <input type="radio"/>		
	PASS <input type="radio"/>	RETURN TO REPAIR <input type="radio"/>		
	FAIL <input type="radio"/>	DESTROY <input type="radio"/>		
	PASS <input type="radio"/>	RETURN TO REPAIR <input type="radio"/>		
	FAIL <input type="radio"/>	DESTROY <input type="radio"/>		
	PASS <input type="radio"/>	RETURN TO REPAIR <input type="radio"/>		
	FAIL <input type="radio"/>	DESTROY <input type="radio"/>		
	PASS <input type="radio"/>	RETURN TO REPAIR <input type="radio"/>		
	FAIL <input type="radio"/>	DESTROY <input type="radio"/>		
	PASS <input type="radio"/>	RETURN TO REPAIR <input type="radio"/>		
	FAIL <input type="radio"/>	DESTROY <input type="radio"/>		
	PASS <input type="radio"/>	RETURN TO REPAIR <input type="radio"/>		
	FAIL <input type="radio"/>	DESTROY <input type="radio"/>		
	PASS <input type="radio"/>	RETURN TO REPAIR <input type="radio"/>		
	FAIL <input type="radio"/>	DESTROY <input type="radio"/>		
	PASS <input type="radio"/>	RETURN TO REPAIR <input type="radio"/>		
	FAIL <input type="radio"/>	DESTROY <input type="radio"/>		
	PASS <input type="radio"/>	RETURN TO REPAIR <input type="radio"/>		
	FAIL <input type="radio"/>	DESTROY <input type="radio"/>		

LIMITED LIFETIME WARRANTY

Warranty to End User: YOKE INDUSTRIAL warrants to the original end user ("End User") that its products are free from defects in materials and workmanship under normal use and service. This warranty extends for the lifetime of the product from the date the product is purchased by the End User, in new and unused condition, from a YOKE INDUSTRIAL authorized distributor. YOKE INDUSTRIAL'S entire liability to End User and End User's exclusive remedy under this warranty is limited to the repair or replacement in kind of any defective product within its lifetime (as YOKE INDUSTRIAL in its sole discretion determines and deems appropriate). No oral or written information or advice given by YOKE INDUSTRIAL, its distributors, directors, officers, agents or employees shall create any different or additional warranties or in any way increase the scope of this warranty. YOKE INDUSTRIAL will not accept liability for defects that are the result of product abuse, misuse, alteration or modification, or for defects that are due to a failure to install, maintain, or use the product in accordance with the manufacturer's instructions.

YOKE INDUSTRIAL'S WARRANTY APPLIES ONLY TO THE END USER. THIS WARRANTY IS THE ONLY WARRANTY APPLICABLE TO OUR PRODUCTS AND IS IN LIEU OF ALL OTHER WARRANTIES AND LIABILITIES, EXPRESSED OR IMPLIED. YOKE INDUSTRIAL EXPRESSLY EXCLUDES AND DISCLAIMS ANY IMPLIED WARRANTIES OF MERCHANTABILITY OR FITNESS FOR A PARTICULAR PURPOSE, AND SHALL NOT BE LIABLE FOR INCIDENTAL, PUNITIVE OR CONSEQUENTIAL DAMAGES OF ANY NATURE, INCLUDING WITHOUT LIMITATION, LOST PROFITS, REVENUES, OR PRODUCTIVITY, OR FOR BODILY INJURY OR DEATH OR LOSS OR DAMAGE TO PROPERTY, UNDER ANY THEORY OF LIABILITY, INCLUDING WITHOUT LIMITATION, CONTRACT, WARRANTY, STRICT LIABILITY, TORT (INCLUDING NEGLIGENCE) OR OTHER LEGAL OR EQUITABLE THEORY.



Safety is our first priority™

YOKE INDUSTRIAL CORP.

#39, 33rd Road, Taichung Industrial Park,

Taichung 407, TAIWAN

Tel:+886-4-2350-8088

Fax:+886-4-2350-1001

E-mail: yoke777@ms74.hinet.net

<http://www.yoke.net>

An ISO 9001 Certified Company